

3D VIEW

NOTES

1. CURRENT RATING: 24V & 3A MAX.
2. CONTACT RESISTANCE: 50mΩ MAX.
3. INSULATION RESISTANCE: 100MΩ MIN.
4. DIELECTRIC WITHSTANDING: 500V AC MIN.
5. DURABILITY: 5000 CYCLES MIN.
6. CONNECTOR MATING FORCES: 3N MIN.
7. CONNECTOR UNMATING FORCES: 35N MAX.
8. OPERATING TEMPERATURE: -25°C TO +85°C.
9. WATER PROOFNESS: THIS PRODUCT IS BASED ON IPX7.

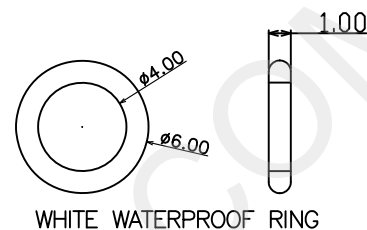
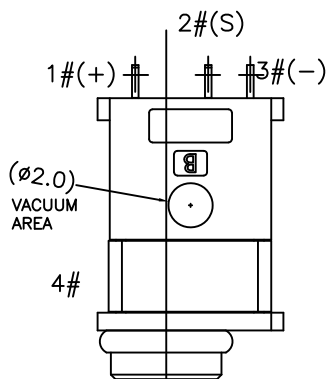
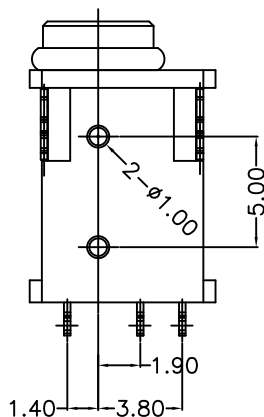

Not to install the waterproof ring shipment

NO.	DESCRIPTION	MATERIAL	REMARKS	QTY
8	WATERPROOF RING	SILICONE	WHITE	1
7	GLUE	EPOXY	COLOR BLACK	1
6	BACK COVER	HIGH TEMPERATURE	COLOR BLACK	1
5	HOUSING	HIGH TEMPERATURE	COLOR BLACK	1
4	TERMINAL 4#	STAINLESS STEEL	NICKEL PLATING OVERALL	1
3	TERMINAL 3#	COPPER ALLOY	NICKEL UNDERPLATING OVERALL, Au PLATING ON THE SOLDER AREA	1
2	TERMINAL 2#	COPPER ALLOY	NICKEL UNDERPLATING OVERALL, Au PLATING ON THE WHOLE	1
1	CENTER PIN	COPPER ALLOY	NICKEL UNDERPLATING OVERALL, Au PLATING ON THE SOLDER AREA	1

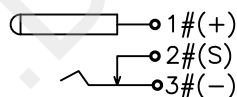
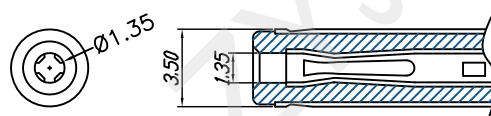
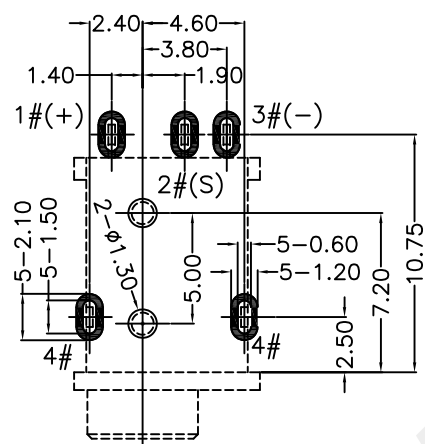

Circuit Diagram

PCB LAYOUT (TOP VIEW)
TOLERANCE: ±0.05



深圳市华宇创精密电子有限公司

TOLERANCE: X.X ±0.30 X.XX ±0.25 X.XXX ±0.15 X' ±2' X.X' ±0.5'	DRAWN BY : 陈一鸣	DATE : 2014-02-23	PART NAME: 防水DC座 DC-1839
	CHECKED BY: 马跃	DATE : 2014-02-23	PART NO. : HVC-DC1839-130
UNIT: mm [inch] SCALE:1:1 SIZE: A4	APPROVED BY: 邱敏	DATE : 2014-02-23	DRAW NO. : HVC-2211021620
			SHEET NO. : 1 OF 1